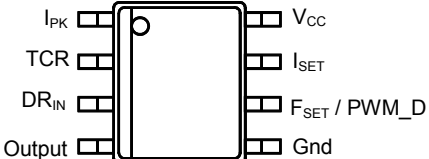
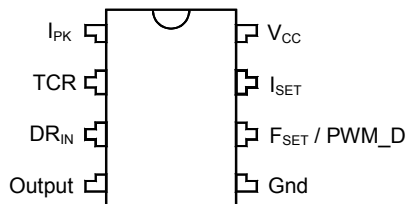

1.0A Power LED Driver with Dimming Control

SMD733

FEATURES	DESCRIPTION
<ul style="list-style-type: none"> ■ Operation from 3.0V to 40V Input ■ Low Standby Current ■ Current Limiting ■ I_{PK} current up to 1.0A ■ Output Current Adjustable ■ Frequency Operation to 100kHz ■ Precision 2% Reference ■ Dimming by PWM or Voltage Adjustment 	<p>The SMD733 Series is a monolithic control circuit containing the primary functions required for DC-to-DC converters. These devices consist of an internal temperature compensated reference, comparator, controlled duty cycle oscillator with an active current limit circuit, driver and high current output switch. This series is specifically designed to be incorporated in Step-Down application with dimming feature with a minimum number of external components.</p>

APPLICATIONS
<ul style="list-style-type: none"> ■ LED Lighting ■ LED Monitors ■ LED Scanners ■ Automotive LED Lighting

PACKAGE/ORDER INFORMATION	
 <p style="text-align: center;">8-Pin Plastic SOIC Surface Mount (Top View)</p>	<p style="text-align: center;">Order Part Number</p> <p style="text-align: center;">SMD733MST</p>
 <p style="text-align: center;">8-Pin Plastic DIP (Top View)</p>	<p style="text-align: center;">SMD733M</p>

PIN FUNCTIONS

Pin No.	Pin Name	Function
1	I_{PK}	Peak Current Limit
2	TCR	Temperature Compensation Reference
3	DR_{IN}	Driver Input
4	Output	Output
5	Gnd	Ground
6	F_{SET} / PWM_D	Frequency Set and PWM Dimming
7	I_{SET}	Output Current Set
8	V_{CC}	V_{CC}

ABSOLUTE MAXIMUM RATINGS (Note 1)

Power Supply Voltage	40V
Comparator Input Voltage Range	$-0.3V \leq V \leq 40V$
Driver Current Input Voltage	40V
Output Voltage	40V
TCR Voltage	40V
TCR Current	100mA
Output Current	1.5A
Operating Ambient Temperature Range	0°C – 70°C
Storage Temperature Range	-65°C to +150°C
Operating Junction Temperature	+150°C

Note 1: Exceeding these ratings could cause damage to the device. All voltages are with respect to ground. Currents are positive into, negative out of the specified terminal.

POWER DISSIPATION TABLE

DIP 8 Package

Power dissipation (P_D), $T_A = 25^\circ\text{C}$	1.31W
Thermal Resistance-Junction to Ambient, θ_{JA}	95°C /W

SOIC 8 Package

Power dissipation (P_D), $T_A = 25^\circ\text{C}$	757mW
Thermal Resistance-Junction to Ambient, θ_{JA}	165°C /W

BLOCK DIAGRAM

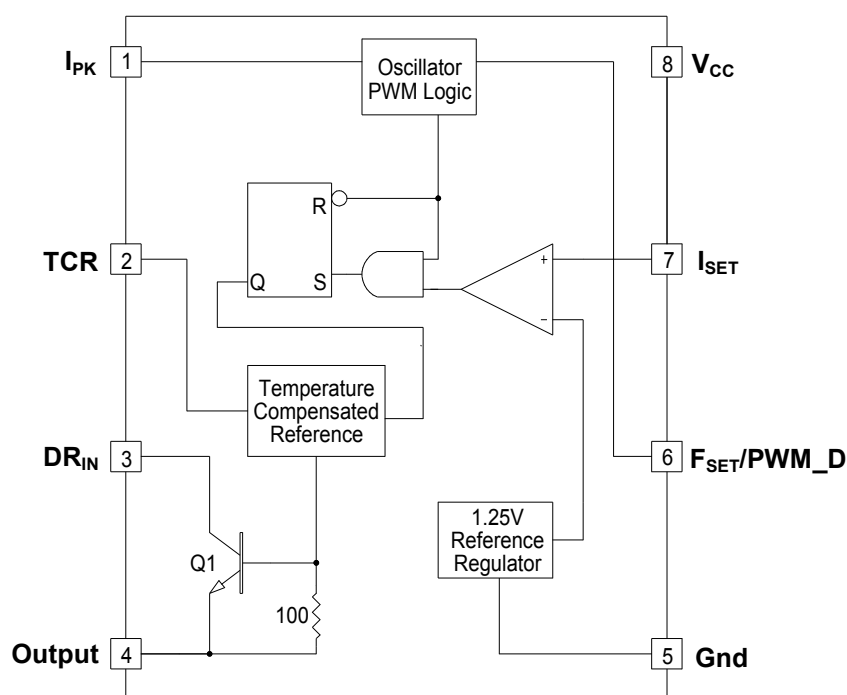

TYPICAL APPLICATIONS

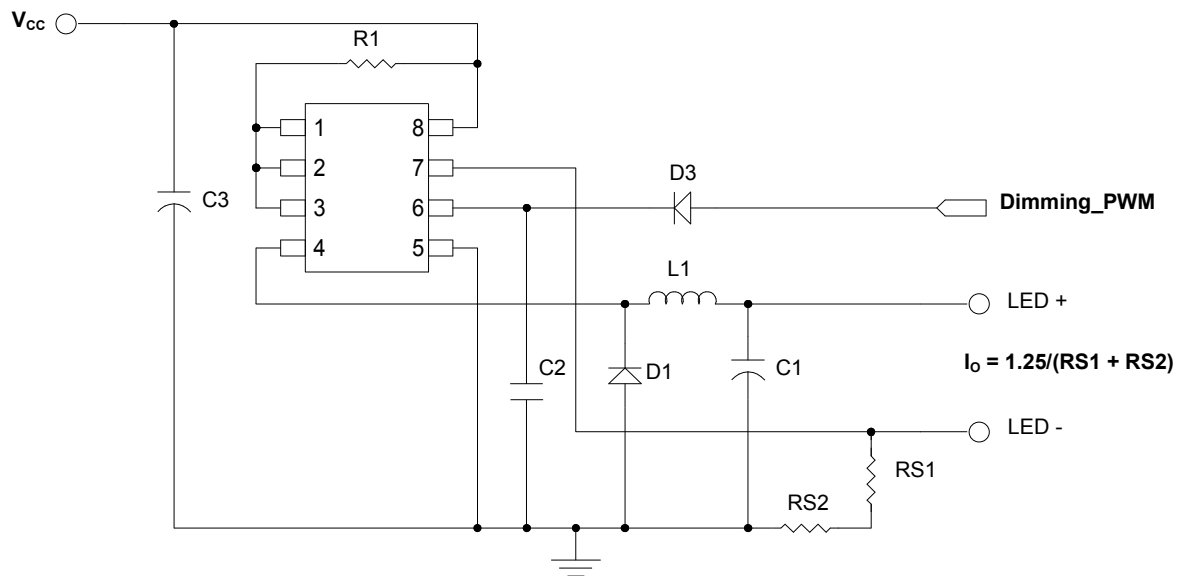

Figure 1 - PWM Dimming Application Circuits

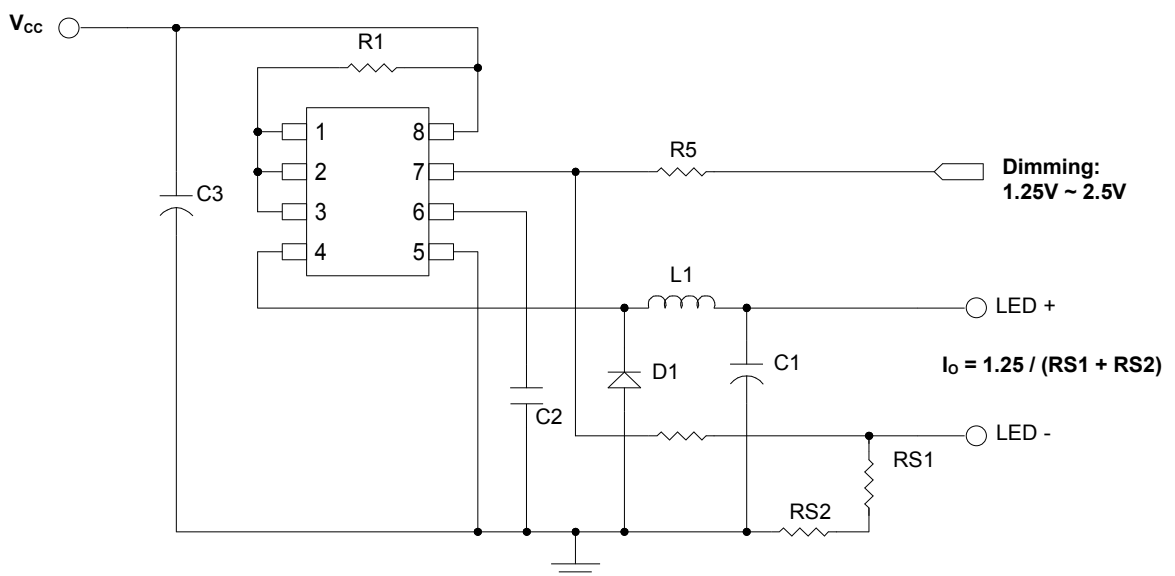

Figure 2 - Voltage Dimming Application Circuits

TYPICAL APPLICATIONS (cont'd)

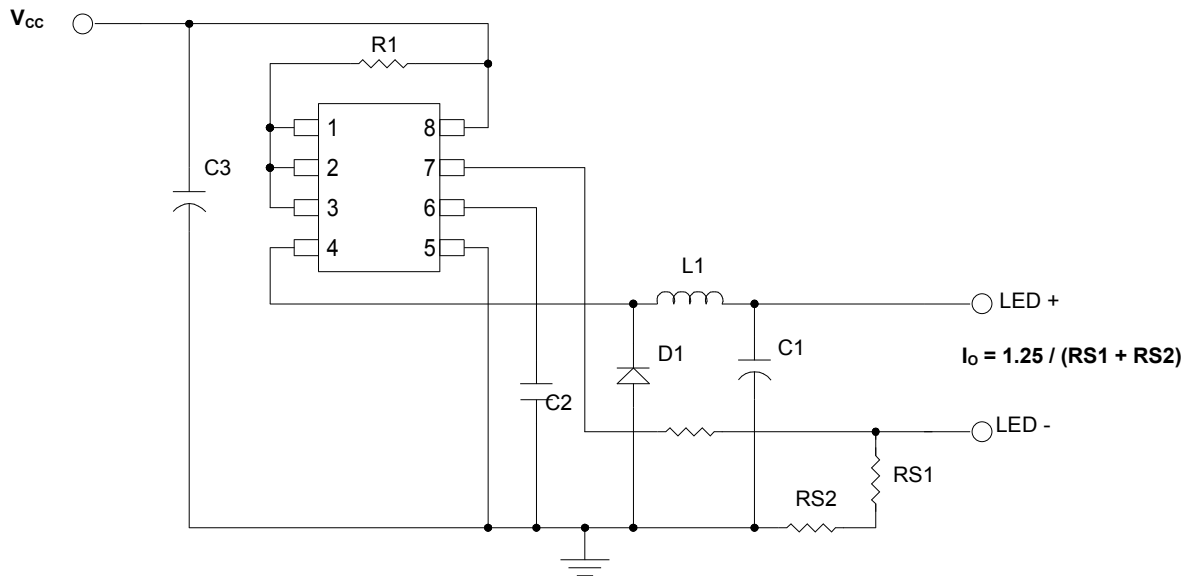

Figure 3 - No Dimming Application Circuits

TYPICAL APPLICATIONS (Design Reference Table)

Calculation	Step-Down
t_{on}/t_{off}	$\frac{V_{out} + V_F}{V_{in(min)} - V_{sat} - V_{out}}$
$t_{on} + t_{off}$	$\frac{1}{f}$
t_{off}	$\frac{t_{on} + t_{off}}{t_{on}/t_{off} + 1}$
t_{on}	$(t_{on} + t_{off}) - t_{off}$
C_T	$4.0 \times 10^{-5} t_{on}$
$I_{pk(switch)}$	$2I_{out(max)}$
R_{SC}	$0.3/I_{pk(switch)}$
$L_{(min)}$	$\left(\frac{V_{in(min)} - V_{sat} - V_{out}}{I_{pk(switch)}} \right) t_{on(max)}$
C_O	$\frac{I_{pk(switch)} (t_{on} + t_{off})}{8V_{ripple(pp)}}$

V_F : Forward Voltage drop of the output rectifier

V_{sat} : Saturation voltage of the output switch.

The following power supply characteristics must be chosen:

- V_{in} - Nominal input voltage
- I_{SET} - Desired output current, $I_{SET} = 1.25 / (RS1 + RS2)$
- V_{OUT} - See LED's V_F
- f_{min} - Minimum desired output switching frequency at the selected values of V_{in} and I_O
- $V_{ripple(pp)}$ - Desired peak – to – peak output ripple voltage.

Application concerns:

To get the best regulation performance, Low ESR capacitors at V_{out} are suggested.

ELECTRICAL CHARACTERISTICS

Unless otherwise specified, these specifications apply $V_{CC} = 5.0\text{ V}$, $T_A = 0^\circ\text{C}$ to 70°C

Parameter	Test Conditions	Min	Typ	Max	Units
Frequency	$V_{PIN7} = 0\text{ V}$, $C_{PIN6} = 1.0\text{ nF}$, $T_A = 25^\circ\text{C}$	24	33	42	KHz
Charge Current	$V_{CC} = 5.0\text{V to }40\text{V}$, $T_A = 25^\circ\text{C}$	24	35	42	μA
Discharge Current	$V_{CC} = 5.0\text{V to }40\text{V}$, $T_A = 25^\circ\text{C}$	140	220	260	μA
Discharge to Charge Current Ration	Pin 1 to V_{CC} , $T_A = 25^\circ\text{C}$	5.2	6.5	7.5	-
Current Limit Sense Voltage	$I_{chg} = I_{dschg}$, $T_A = 25^\circ\text{C}$	250	300	350	mV
Saturation Voltage 1	$I_{SW} = 1.0\text{A}$, Pins 2, 3 connected	-	1.0	1.3	V
Saturation Voltage 2	$I_{SW} = 1.0\text{A}$, $R_{PIN2} = 82\Omega$ to V_{CC} , Force $\beta = 20$		0.45	0.7	V
DC Current Gain	$I_{SW} = 1.0\text{A}$, $V_{CE} = 5.0\text{V}$, $T_A = 25^\circ\text{C}$	50	75		
Collector Off-State Current	$V_{CE} = 40\text{V}$		0.01	100	μA
Threshold Voltge	$T_A = 25^\circ\text{C}$	1.225	1.25	1.275	V
Input Bias Current	$V_{IN} = 0\text{V}$		-20	-400	nA
Supply Current	$V_{CC} = 5.0\text{V to }40\text{V}$, $C_{PIN6} = 1.0\text{ nF}$, Pin 1 = V_{CC} , $V_{PIN7} > V_{TH}$, Pin 4 = Gnd, remaining pins open			4.0	mA

CHARACTERIZATION CURVES

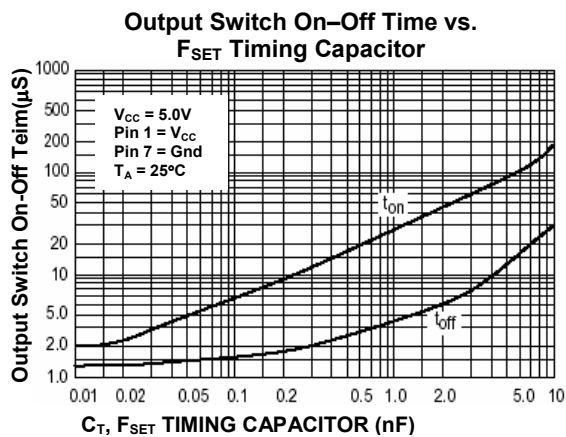
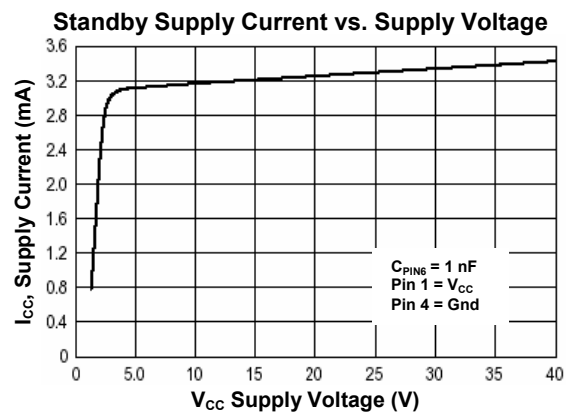
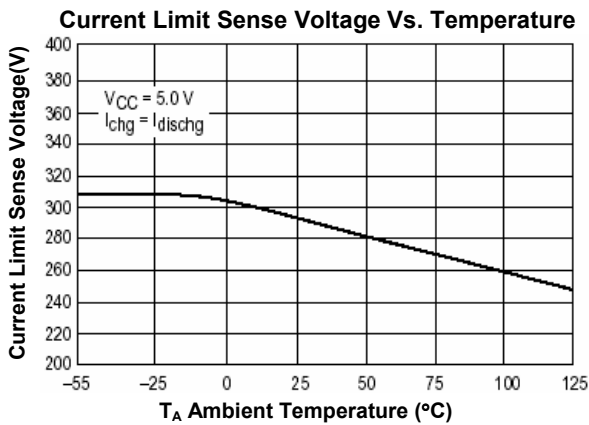
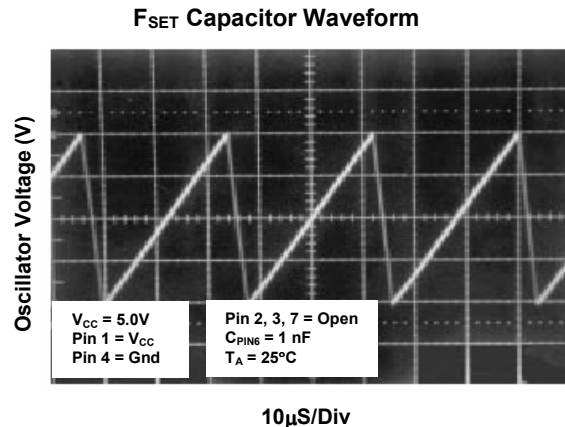
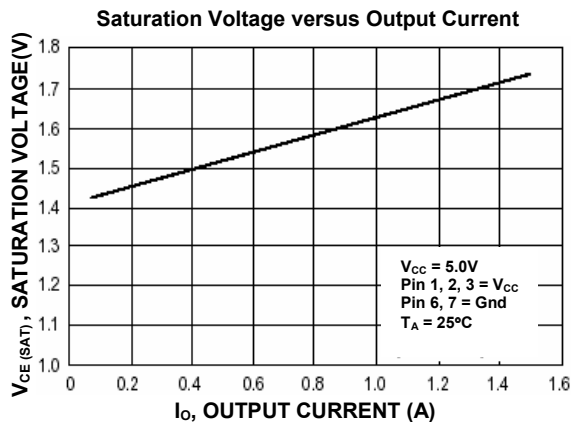

PACKAGE DESCRIPTION Dimensions in inches (millimeters) unless otherwise specified

8 Pin DIP

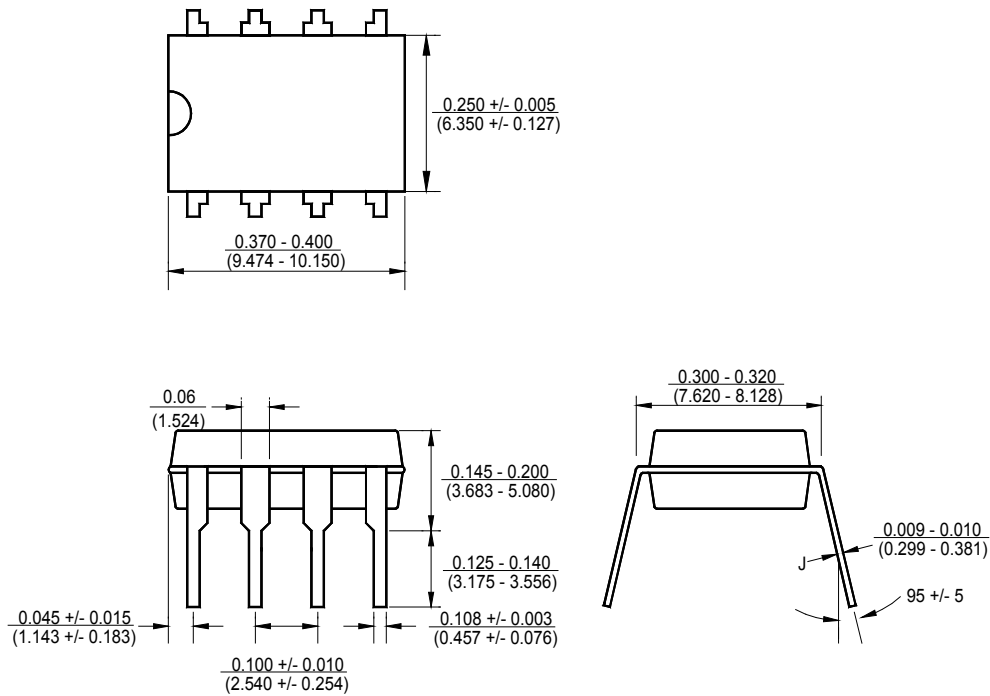

8 Pin SOIC

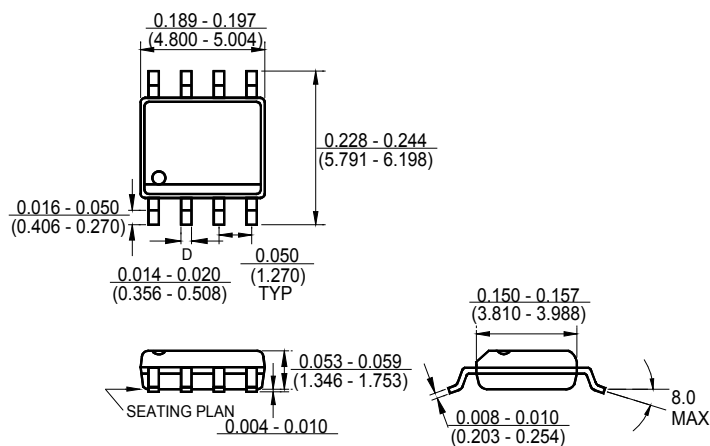

MARKING DIAGRAM

DIP 8

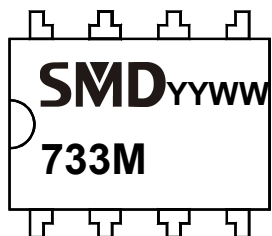

SO 8

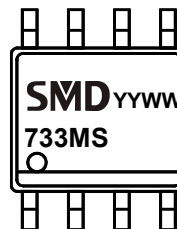

YY = Year, WW = Working Week

IMPORTANT NOTICE

Shamrock Micro Devices (SMD) reserves the right to make changes to its products or to discontinue any integrated circuit product or service without notice, and advises its customers to obtain the latest version of relevant information to verify, before placing orders, that the information being relied on is current.

A few applications using integrated circuit products may involve potential risks of death, personal injury, or severe property or environmental damage. SMD integrated circuit products are not designed, intended, authorized, or warranted to be suitable for use in life-support applications, devices or systems or other critical applications. Use of SMD products in such applications is understood to be fully at the risk of the customer. In order to minimize risks associated with the customer's applications, the customer should provide adequate design and operating safeguards.